

BI-METAL THERMOMETERS





BI-METAL THERMOMETERS

Chicago Stainless Equipment has been manufacturing equipment for the dairy, food processing and pharmaceutical industries for well over half a century. We incorporated over 40 years experience in manufacturing the world's finest sanitary pressure gauges when the Bi-Metal Thermometer was developed. The Bi-Metal Thermometer is built to function for many years with little or no maintenance. Our dedication to quality is not only evident in our products, but also in our customer service. We offer immediate availability on all products and respond quickly with quality service at reasonable prices. We feel so strongly about the quality of our products and service that we guarantee complete satisfaction.

FEATURES

- Standard 304 Stainless Steel Case and Bezel on all external parts increases corrosion resistance.
- Super Sensitive Bimetallic Helix Coil is fabricated to tight tolerances. Heat treated for stress relief and silicone coated to minimize pointer vibration and maximize heat transfer and response time
- Bi-Metal Bushing is pressed into groove on stem to center the coil in stem. 302 stainless steel stem wire through center of bushing connects bimetal element to pointer to minimize coil interference with tube wall.
- C.I.P. - can be cleaned in place for convenience and eliminates the possibility of damage from mishandling.
- Temperature Ranges from -100°F (-75°C) to 1000°F (550°C).
- Hermetic Seal on Case/Bezel assembly is a precision interference fit. Silicone gasket provides dustproof and leakproof seal
- External Reset Calibration adjusts using an Allen wrench to discourage tampering.
- Silicone Fill is available on all gauges for additional dampening of extreme vibration, or to assure consistent performance in low process temperature/high environmental humidity
- 140°F (60°C) Maximum process temperature Please consult factory when ordering for higher temperature applications.
- Quick Availability, most orders ship in about 1 week.
- Experienced Engineers are available to answers questions and solve difficult application problems.
- Unparalleled Customer Service where the customer is always right and we are not happy until the customer is satisfied.



SPECIFICATIONS

Accuracy	+/-1% of Full Scale
Over Range Capability	30%
Wetted Surfaces	Sanitary - 316L Stainless Steel Industrial - 304 Stainless Steel
Case Material	304 Stainless Steel
Dial Sizes	3", 4", 5" (76, 102, 127mm) Dia.
Standard Lens	Glass
Optional Lens	Various Shatter-Resistant Materials
Temp. Limits	-100°F/1000°F (-75°C/550°C)
Optional Fill	Silicone
Recalibration Feature	Standard
Dry Shipping Wt. 3", 4", 5"	11 oz, 16 oz, 20 oz
Filled Shipping Wt. 3", 4", 5"	14 oz, 22 oz, 30 oz

AVAILABLE RANGES

20 different temperature ranges are available in both Fahrenheit and Celsius. Refer to back page for specific information.

AVAILABLE FITTINGS

1/2"-18 NPT
3/4" Tri-Clamp*, 1 1/2" Tri-Clamp*, 2" Tri-Clamp*, 2 1/2" Tri-Clamp*, 3" Tri-Clamp*, 4" Tri-Clamp*.

AVAILABLE MOUNTINGS

Bottom, Back and Adjustable mount.

Tri-Clamp is a registered trademark of Tri-Clover, Inc.

SANITARY FITTING DIMENSIONS

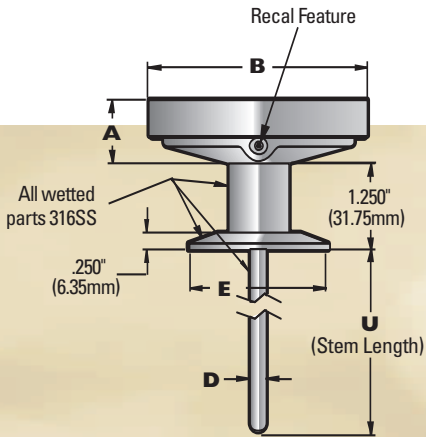

BACK MOUNT
(shown with Tri-Clamp®)

SIZE	A	B
3"	.89" (23mm)	3.19" (81mm)
4"	.89" (23mm)	4.12" (104mm)
5"	1.34" (34mm)	5.04" (128mm)

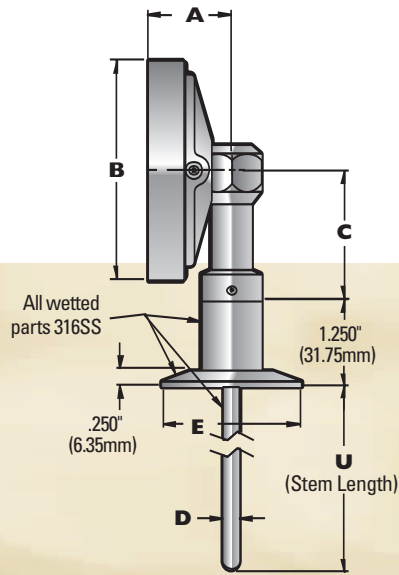

BOTTOM MOUNT
(shown with Tri-Clamp®)

SIZE	A	B	C
3"	1.19" (30mm)	3.19" (81mm)	1.88" (48mm)
4"	1.19" (30mm)	4.12" (104mm)	2.62" (67mm)
5"	1.62" (41mm)	5.04" (128mm)	2.62" (67mm)

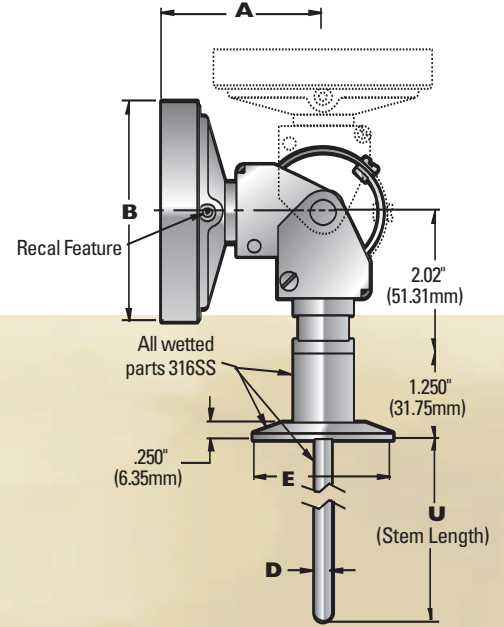

ADJUSTABLE MOUNT
(shown with Tri-Clamp®)

SIZE	A	B
3"	2.43" (62mm)	3.19" (81mm)
4"	2.43" (62mm)	4.12" (104mm)
5"	2.66" (68mm)	5.04" (128mm)

Available Tri-Clamp® Fittings (E): 3/4" Tri-Clamp = .98" (25mm), 1-1/2" Tri-Clamp = 1.98" (50mm), 2" Tri-Clamp = 2.52" (64mm), 2-1/2" Tri-Clamp = 3.05" (77mm), 3" Tri-Clamp = 3.56" (91mm), 4" Tri-Clamp = 4.68" (119mm)
Available Stem Lengths (U): 1.62" (41mm), 2.50" (64mm), 4.50" (114mm), 7.50" (190mm), 10.50" (267mm), 13.50" (343mm), 16.50" (419mm), 22.50" (572mm)

INDUSTRIAL FITTING DIMENSIONS

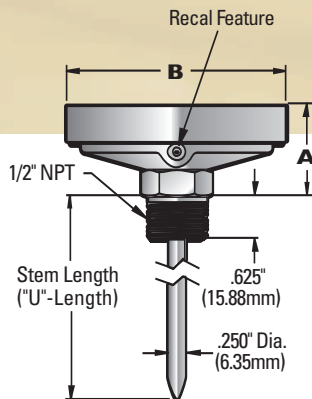

BACK MOUNT
(shown with 1/2" NPT)

SIZE	A	B
3"	1.38" (35mm)	3.19" (81mm)
4"	1.38" (35mm)	4.12" (104mm)
5"	4.72" (44mm)	5.04" (128mm)

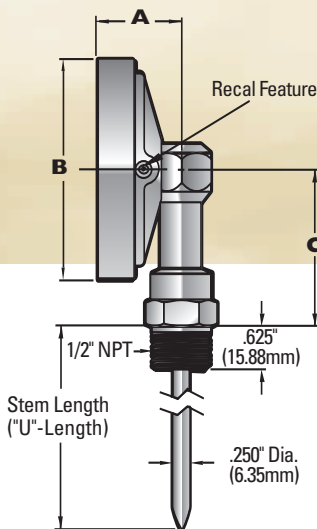

BOTTOM MOUNT
(shown with 1/2" NPT)

SIZE	A	B	C
3"	1.19" (30mm)	3.19" (81mm)	2.30" (58mm)
4"	1.19" (30mm)	4.12" (104mm)	3.00" (76mm)
5"	1.62" (41mm)	5.04" (128mm)	3.00" (76mm)

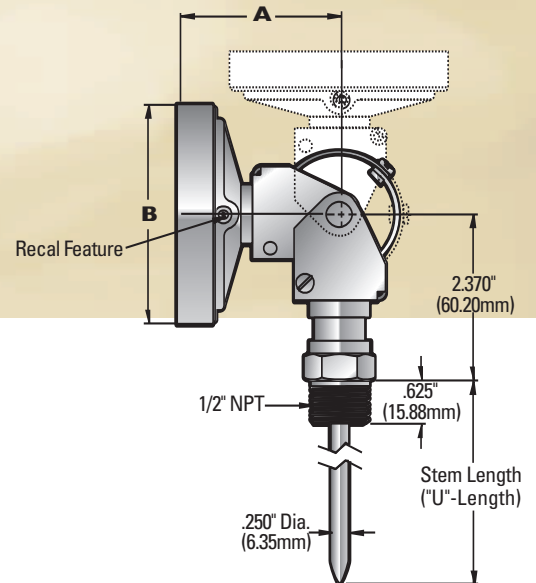

ADJUSTABLE MOUNT
(shown with 1/2" NPT)

SIZE	A	B
3"	2.43" (62mm)	3.19" (81mm)
4"	2.43" (62mm)	4.12" (104mm)
5"	2.66" (68mm)	5.04" (128mm)

Available Stem Lengths (U): 2.50" (64mm), 4.00" (102mm), 6.00" (152mm), 9.00" (229mm), 12.00" (305mm), 15.00" (381mm), 18.00" (457mm), 24.00" (610mm)



BI-METAL THERMOMETERS ORDERING INFORMATION

Below are typical examples of models with their descriptions.

EXAMPLE 1:
3B - T67 - 2U - BK - L4.5 - 3/8 - A
Describes a 3" (76mm) Bi-metal Thermometer, 0 to 250°F, 2" Tri-Clamp fitting, back mounted, 4½" Probe Length with a .375" probe diameter, standard glass lens.

EXAMPLE 2:
4B - T87 - 3U - BT - L22.5 - 3/8 - C
Describes a 4" (102mm) Bi-metal Thermometer, -75° to 175°C, 3" Tri-Clamp fitting, bottom mounted, 22½" probe length with a .375" probe diameter, safety glass lens.

EXAMPLE 3:
5B - T61 - ½NPT - AA - L7.5 - 3/8 - E
Describes a 5" (127mm) Bi-metal Thermometer, 50 to 250°F, ½" NPT fitting, adjustable angle, 7½" probe length with a .375" probe diameter, polycarbonate lens.

MODEL NUMBER CONSISTS OF:

SERIES - TEMP. RANGE - FITTING - MOUNT - PROBE LENGTH - PROBE DIA. - LENS
3B T67 2U BK L4.5 3/8 A

Please make a selection from each category below:

SERIES

- 3B 3" Dial
- 4B 4" Dial
- 5B 5" Dial

TEMPERATURE RANGE

- | | |
|-----------------|----------------|
| T51 -100/100°F | T87 -75/175°C |
| T52 -50/120°F | TEA -70/70°C |
| T53 -40/160°F | T71 -50/100°C |
| T54 0/140°F | T72 -50/25°C |
| T55 0/180°F | T73 -50/50°C |
| T50 0/200°F | T84 -40/70°C |
| T56 0/220°F | T86 -20/120°C |
| T67 0/250°F | T74 -10/110°C |
| T57 0/300°F | T75 0/50°C |
| T58 0/500°F | T95 0/60°C |
| T59 20/240°F | TEI 0/80°C |
| T60 25/125°F | T76 0/100°C |
| T61 50/250°F | T77 0/150°C |
| T62 50/300°F | T78 0/200°C |
| T63 50/400°F | T79 0/250°C |
| T64 50/500°F | T80 0/300°C |
| T68 50/550°F | T81 0/400°C |
| T44 100/800°F | T90 0/450°C |
| T65 150/750°F | T82 100/400°C |
| T66 *200/1000°F | T83 *100/550°C |

*Not for continued use above 800°F (425°C) (for intermittent use only).
Ranges vary by dial size and fitting.

FITTING

- ¾ U ¾" Tri-Clamp (3 16SS)*
- 1 ½ U 1 ½" Tri-Clamp (3 16SS)**
- 2U 2" Tri-Clamp (3 16SS)
- 2 ½ U 2 ½" Tri-Clamp (3 16SS)
- 3U 3" Tri-Clamp (3 16SS)
- 4U 4" Tri-Clamp (3 16SS)
- ½ NPT ½" NPT (3 16SS)

* Used on both ½" and ¾" lines.
** Used on both 1" and 1 ½" lines.

MOUNT

- BT Bottom Mount
- BK Back Mount
- AA Adjustable Angle

PROBE LENGTH (U)

- | | |
|--------------------|---------------------------|
| L2.5 2 ½" (½" NPT) | L1.625 1.625" (Tri-Clamp) |
| L4 4" (½" NPT) | L2.5 2.5" (Tri-Clamp) |
| L6 6" (½" NPT) | L2.75 2.75" (Tri-Clamp) |
| L9 9" (½" NPT) | L4.5 4.5" (Tri-Clamp) |
| L12 12" (½" NPT) | L7.5 7.5" (Tri-Clamp) |
| L15 15" (½" NPT) | L10.5 10.5" (Tri-Clamp) |
| L18 18" (½" NPT) | L13.5 13.5" (Tri-Clamp) |
| L24 24" (½" NPT) | L16.5 16.5" (Tri-Clamp) |
| L30 30" (½" NPT) | L22.5 22.5" (Tri-Clamp) |
| L36 36" (½" NPT) | |
| L42 42" (½" NPT) | |

PROBE DIAMETER (D)

- 1 5/64 .236"
- 1/4 .250" Standard on NPT
- 5/16 .315"
- 3/8 .375" Standard on Tri-Clamp

LENS

- A Glass (Standard)
- B Tempered Glass
- C Safety Glass
- D Plastic, Acrylic
- E Plastic, Polycarbonate

Visit our website or request a catalog to see our complete line of high quality precision products including: Sani-Flow Pressure Gauges, Homogenizer Pressure Gauges, Industrial Stainless Steel Pressure Gauges, Digital Thermometers, Pharma-Flow Pressure Gauges, Chem-Flow Pressure Gauges, Electronic Sensors Cable, Sanitary Temperature Sensors & Thermowells.

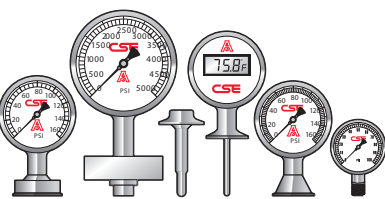

DISTRIBUTED BY:

For more information or for a distributor in your area, contact us:
Chicago Stainless Equipment
772-781-1441
www.chicagostainless.com