

PHARMA-FLOW SANITARY PRESSURE GAUGES



QUALITY PRODUCTS SINCE 1937
www.ChicagoStainless.com

Since 1937, Chicago Stainless Equipment has been manufacturing Sanitary Equipment for the food industry. Our Pharmaceutical Pressure Gauge was designed to be our *top of the line* pressure gauge geared towards pharmaceutical use. The gauges on our Pharma-Flow line are our most accurate and most hygienic pressure gauge. They contain a flush mounted diaphragm with no sharp corners or crevices. This eliminates the possibility of any contaminants, making it the industry’s most sanitary pressure gauge available. These gauges are calibrated with an accuracy of +/-0.75%, while the product contact surface is mechanically ground to a mirror-like finish. Our Pharma-Flow line complies fully with the 3-A Sanitary Standards.

All of our pressure gauges are built to withstand the harshest environments and function for many years with little to no maintenance. Our dedication to quality is not only evident in our products, but also in our customer service. CSE commits to offering the highest level of product and resources to every customer. We provide efficient, quick, and friendly service along with striving to build relationships with all of our partners.

KEY FEATURES

316L Stainless Steel Sanitary Fittings and Diaphragms	Assures maximum corrosion resistance while providing the most sanitary construction possible
304L Stainless Steel Case	For durability even in the harshest environments
Polycarbonate Lens	Ensures durability
Waterproof Construction	Allows gauge to be submersed for cleaning
Clean-In-Place (CIP)	Can be cleaned in place for convenience and to eliminate the possibility of damage from mishandling
Pressure Ranges	Available from 30 psi up to 1,000 psi Also available in vacuum ranges
Dial Face Sizes	Available in 2½", 3½", 4" or 5"
Flush Diaphragm	No sharp edges or corners. Eliminating the possibility of any contaminants.
True Zero with Re-Zero Feature	Standard on all Sanitary Gauges
Unique Pulsation Dampening System	To insulate the gauge movement from punishing pulsations which shorten the life of an ordinary pressure gauge
Glycerin Fill	Standard to protect the gear mechanism against wear
350°F Maximum Process Temperature (176°C)	With high temperature option

TYPICAL INDUSTRIES

- Pharmaceutical
- Biotechnology
- Specialized OEM Equipment
- Food
- Beverage
- Citrus
- Meat / Poultry
- Distillery
- Winery
- Cosmetic

SPECIFICATIONS

TOLERANCES:

Compliance:	ANSI / 3-A, NEMA 4X, IP67, ISO 9001:2015
Accuracy:	±0.75% of Full Range
Over Range Capability:	30% Over Range
Repeatability:	±0.5% of Full Scale
Linearity:	±0.5% of Full Scale
Hysteresis:	±0.5% of Full Scale
Process Temperature Range:	10° to 250°F (-12° to 121°C) *
Ambient Operating Limits:	25° to 160°F (-4° to 71°C)
Ambient Storage Limits:	0° to 250°F (-18° to 121°C)

* High Temperature Option increases maximum process temperature to 350°F (176°C)

CONSTRUCTION:

Product Contact Material:	316L Stainless Steel
Product Contact Finish:	R _a max = 8µin (0.20µm) *
Case and Lens Ring Material:	304L Stainless Steel
Lens Material:	1/4" Polycarbonate
Dial Face:	Aluminum Printed with UV Inks (No Stickers)
Bourdon Tube & Socket: (3½" and 5" Dial)	Phosphor Bronze & Brass
Bourdon Tube & Socket: (2½" and 4" Dial)	316L Stainless Steel
Re-Zero Adjustment:	Standard on all Sanitary Gauges - 100% of Span
Standard Case Fill:	99.7% USP Food Grade Glycerin **
Standard System Fill	99.7% USP Food Grade Glycerin **
Approx. Shipping Weight (2½"):	1 Pounds (0.5 Kg)
Approx. Shipping Weight (3½"):	3 Pounds (1.4 Kg)
Approx. Shipping Weight (5"):	5 Pounds (2.3 Kg)

* Other diaphragm options available - See website or contact us

** Other fill options available - See website or contact us

MADE IN THE USA

Chicago Stainless Equipment, Inc products are proudly manufactured in the USA.



PART NUMBERS

Example: **3P-DB-15I-GF-BK-CC-CD - CSE**

SERIES

2-1/2" Pharma-Flow Pressure Gauge	2P	4" Pharma-Flow Pressure Gauge	4P
3-1/2" Pharma-Flow Pressure Gauge	3P	5" Pharma-Flow Pressure Gauge	5P

SINGLE SCALE

<u>RANGE</u>	<u>PSI</u>	<u>BAR</u>	<u>kg/cm²</u>	<u>kPa</u>	<u>MPa</u>	<u>Tons/Ft²</u>	<u>Atmospheres</u>
0 to 30	B	2BAR	2KG	200KPA		2TON	2ATM
0 to 60	C	4BAR	4KG	400KPA		4TON	4ATM
0 to 100	D	7BAR	7KG	700KPA		7TON	7ATM
		10BAR	10KG	1000KPA		10TON	10ATM
0 to 160	E	11BAR	11KG	1100KPA	1.1MPA	11TON	11ATM
0 to 200	F	14BAR	14KG		1.4MPA	14TON	14ATM
0 to 300	G	21BAR	21KG		2.1MPA	21TON	21ATM
0 to 400	H	28BAR	28KG		2.8MPA	28TON	28ATM
0 to 600	I	42BAR	42KG		4.2MPA	42TON	42ATM
0 to 1,000	K	70BAR	70KG		7MPA	70TON	70ATM
30"Hg to 30	M	-1/2BAR	-1/2KG	-100/200KPA		-1/2TON	-1/2ATM
30"Hg to 60	N	-1/4BAR	-1/4KG	-100/400KPA		-1/4TON	-1/4ATM
30"Hg to 100	O	-1/7BAR	-1/7KG	-100/700KPA		-1/7TON	-1/7ATM
30"Hg to 150	P	-1/10BAR	-1/10KG	-100/1000KPA	-.1/1MPA	-1/10TON	-1/10ATM
30"Hg to 200	Q	-1/14BAR	-1/14KG		-.1/1.4MPA	-1/14TON	-1/14ATM
30"Hg to 300	R	-1/21BAR	-1/21KG		-.1/2.1MPA	-1/21TON	-1/21ATM

OR

DUAL SCALE

<u>RANGE</u>	<u>PSI-BAR</u>	<u>PSI & kg/cm²</u>	<u>PSI & kPa</u>	<u>PSI & MPa</u>	<u>PSI & Tons/Ft²</u>	<u>PSI & Tons/Ft²</u>
0 to 30	BB	BKG	BKP		BTON	BATM
0 to 60	CB	CKG	CKP		CTON	CATM
0 to 100	DB	DKG	DKP		DTON	DATM
0 to 160	EB	EKG	EKP	EMPA	ETON	EATM
0 to 200	FB	FKG		FMPA	FTON	FATM
0 to 300	GB	GKG		GMPA	GTON	GATM
0 to 400	HB	HKG		HMPA	HTON	HATM
0 to 600	IB	IKG		IMPA	ITON	IATM
0 to 1,000	KB	KKG		KMPA	KTON	KATM
30"Hg to 30	MB	MKG	MKP		MTON	MATM
30"Hg to 60	NB	NKG	NKP		NTON	NATM
30"Hg to 100	OB	OKG	OKP		OTON	OATM
30"Hg to 150	PB	PKG	PKP	PMPA	PTON	PATM
30"Hg to 200	QB	QKG		QMPA	QTON	QATM
30"Hg to 300	RB	RKG		RMPA	RTON	RATM

PART NUMBERS CONT...

Example: **3P-DB-15I-GF-BK-CC-CD - CSE**

FITTING SIZE (By Inch)

FITTING TYPE

1-1/2" HAS A CODE OF "15"

3/4 *	1-1/2	2	2-1/2	3	Tri-Clamp	U
1-1/2	2				G&H Male H-Line	H
1-1/2	2	2-1/2	3		Cherry Burrell Male I-Line	I
1-1/2	2				Cherry Burrell Q-Clamp	Q
1-1/2	2				#15 Bevel Seat Male (Threaded)	S
1-1/2	2				#14 Bevel Seat Female (w/#13H Nut)	T
50mm	68mm				Varinline (Tuchenhagen)	50V or 68V

* 3/4" Tri-Clamp only available with 2 1/2" Dial Face

CASE FILL

MOUNT STYLE

Glycerin Filled Case * STANDARD *	GF	Bottom Mount	BT
No Fill	NF	Center Back Mount	BK
Mineral Oil Filled Case	MF	Left Side Mount	LF
Silicone Filled Case	SF	Right Side Mount	RT
Propylene Glycol Filled Case	PF	Top Mount	TP

LOGO * CUSTOM LOGOS AVAILABLE UPON REQUEST *

Chicago Stainless Equipment, Inc * STANDARD *	CSE
---	-----

ADDITIONAL OPTIONS

Glass Lens	3GL or 5GL	General Calibration Certificate	CG
Drag Pointer 3/2" & 5" Only	DRAG3 or DRAG5	Detailed Calibration Certificate	CD
High Temperature Option	VI	Material Test Report	MTR
Custom Color Ranged Dial	CR	Certificate of Conformity	CC
Extra Dampening N/A on 3/4" Fittings	XD	Paper Tag	PTI
Mineral Oil System Fill N/A on 3/4" Fittings	MSF	Stainless Steel Tag	STI
Silicone System Fill	SSF	Animal Derived Ingredient Free Cert	ADIF
Propylene Glycol System Fill	PSF	Hastelloy Diaphragm	HD
High Visibility Dial Face - Yellow	HVY	Electropolish	EPL
High Visibility Dial Face - Green	HVG		

REPAIR

We offer repairs on all of our Pharmaceutical Pressure Gauges. All repair orders must be through a CSE authorized distributor. You may ship your Pressure Gauge to our facility at...

Chicago Stainless Equipment, Inc
ATTN: REPAIRS
1280 SW 34th St
Palm City, FL 34990

** Please always include a Purchase Order inside of the box to prevent loss of your item **

- Your item(s) will be evaluated by our skilled technicians and if they find any issues that may deem the gauge(s) to be damaged beyond repair, a member of our Sales Team will reach out to the contact provided on your Purchase Order.
- We do NOT repair by replacement. The Pressure Gauge you send in is the Pressure Gauge you will receive back to you.
- Although we do not require an RMA for repairs, you may request one by email at Sales@ChicagoStainless.com

RECALIBRATION

If you are looking for your Pressure Gauge to be recalibrated and do not believe a repair is needed, you may send in a Pressure Gauge the same way as stated above.

- Recalibration with or without certifications can only be completed on an instrument that has not been damaged and is functioning properly.

If the gauge is found to be damaged or not functioning for any reason, it must first be repaired. After repair of the gauge, it will automatically be recalibrated.

- Any type of recertification can be requested with an additional fee.

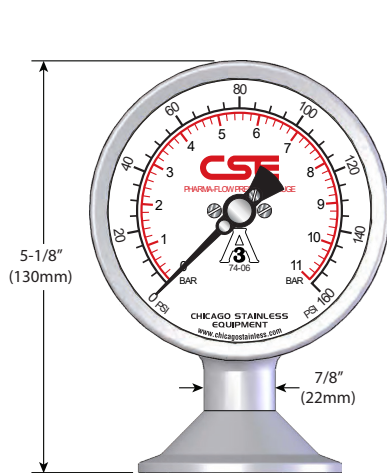

3-1/2" BOTTOM MOUNT
(Shown with 2" Tri-Clamp)

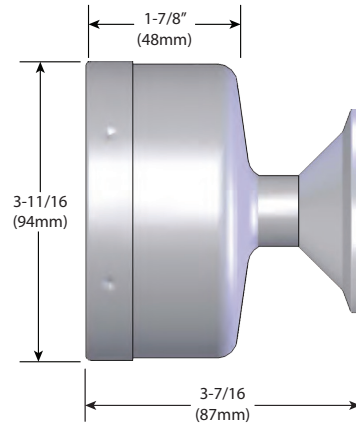
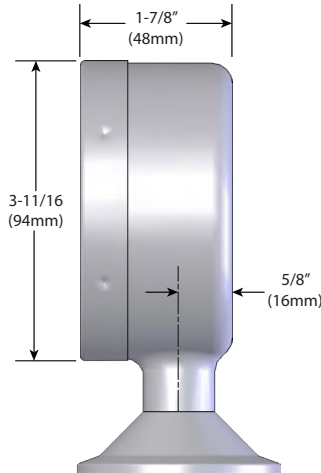

3-1/2" BACK MOUNT
(Shown with 2" Tri-Clamp)

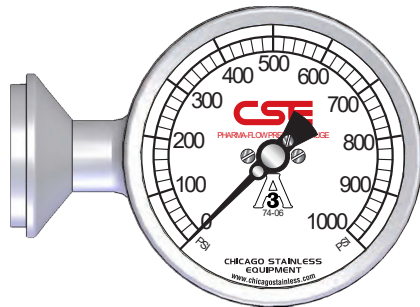

3-1/2" LEFT SIDE MOUNT
(Shown with 1-1/2" Male I-Line)



3-1/2" TOP MOUNT
(Shown with 2" Male I-Line)

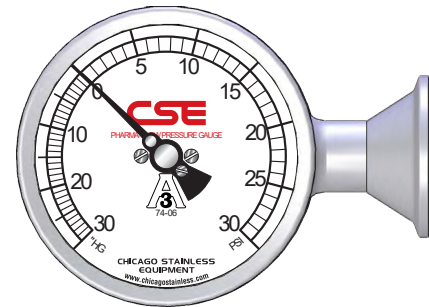

3-1/2" RIGHT SIDE MOUNT
(Shown with 1-1/2" Tri-Clamp)

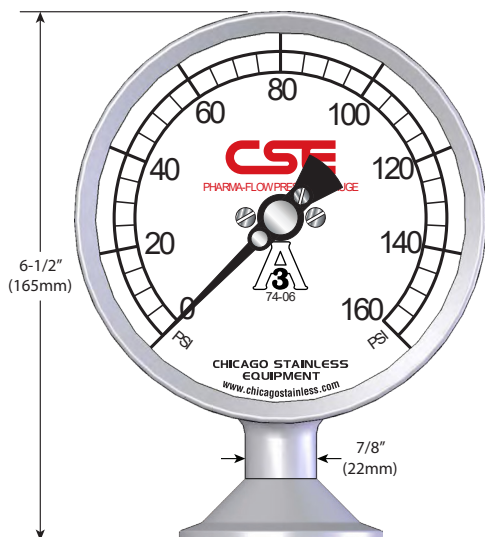

5" BOTTOM MOUNT
(Shown with 2" Tri-Clamp)

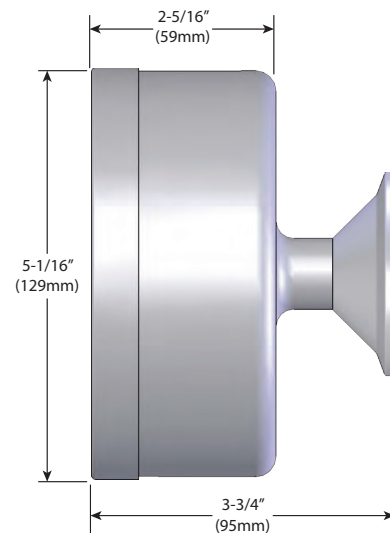
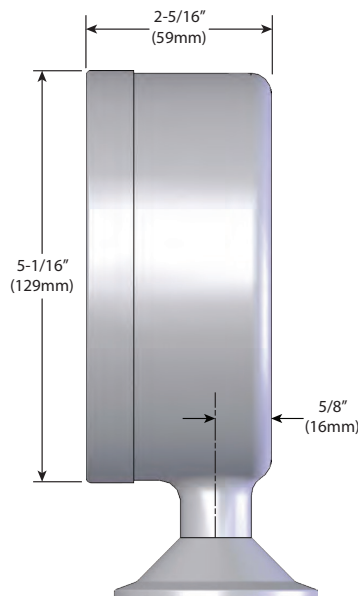

5" BACK MOUNT
(Shown with 2" Tri-Clamp)

BOTTOM MOUNT

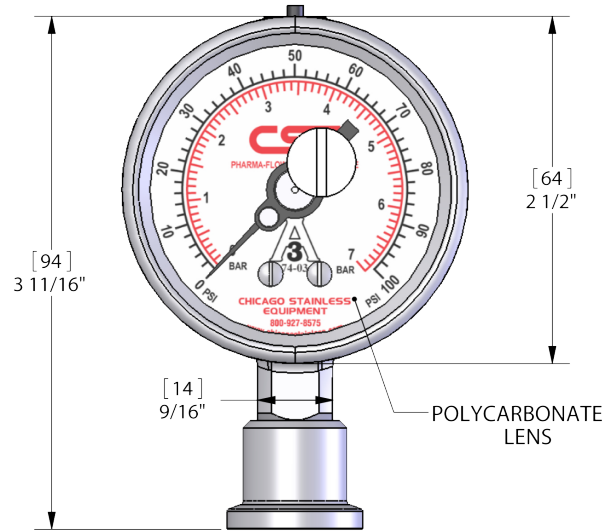
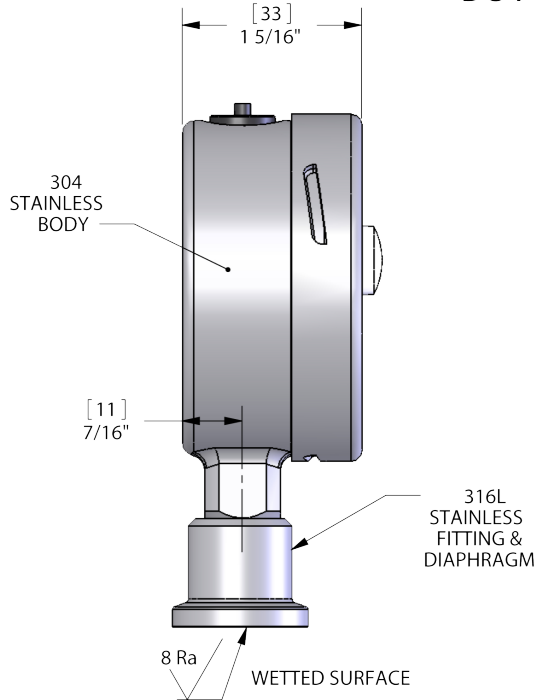

BACK MOUNT

